

STAINES DSD18

DROP SIDE DUMPER—18 TONNE



Our Staines Tandem axle drop side dumper has versatility in applications for the transport of aggregates, top soil, construction debris etc. making it suitable for a multitude of applications from agricultural to small construction sites.

Complete with a heavy duty body, automatic rear door and three stage tipping ram. Our Staines drop down dumpers have the ability to drop near and off sides making loading pallets or bags onto this heavy duty trailer an ease.

TRAILER SPECIFICATION

Model	DSD18-A
Carrying Capacity	18 tonne
Floor	8mm Mild Steel
Sides	5mm Mild Steel
Trailer Chassis	250 x 150 x 8mm RHS
Axles	Commercial 10 stud
Suspension	Commercial parabolic mono leaf suspension
Tyres	385 / 65 R22.5
Braking	Hydraulic Braking system
Lighting	Fully road legal LED lighting kit Rear stop/ tail / Indicator/ Flashing light Front & Side LED marker lights
Paint	Twin pack, high gloss polyurethane paint

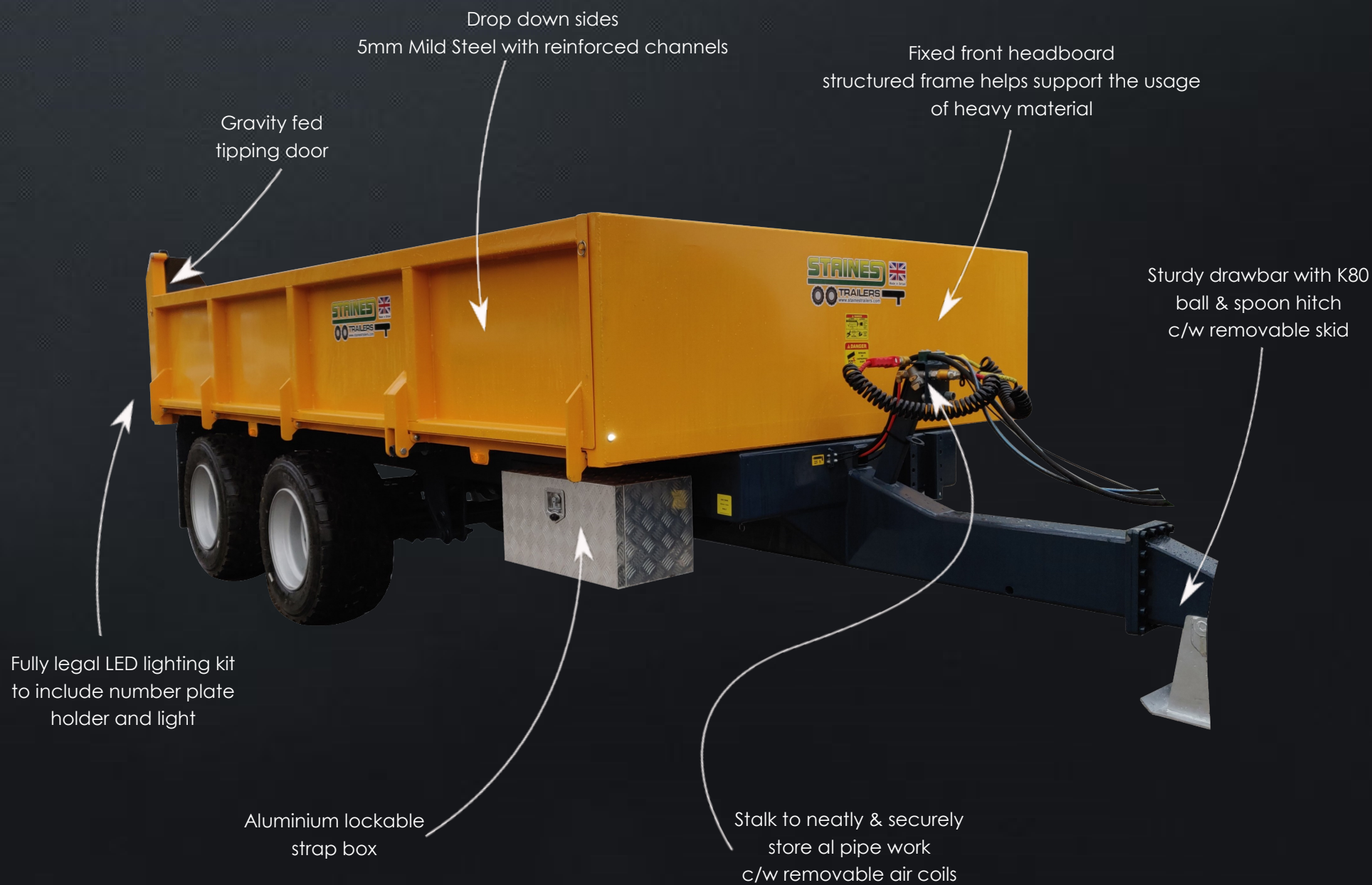

STAINES DSD18

DROP SIDE DUMPER—18 TONNE

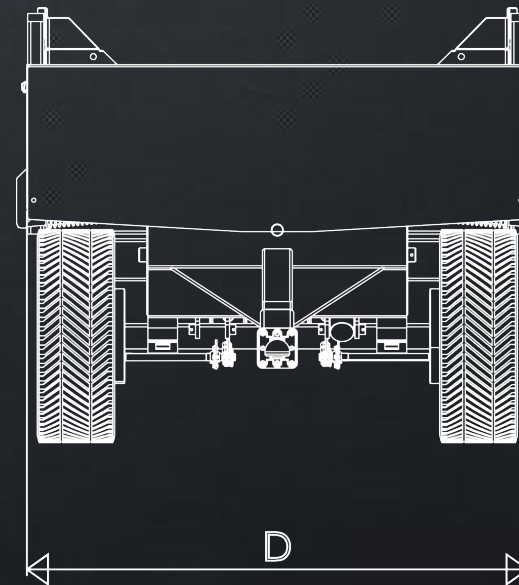
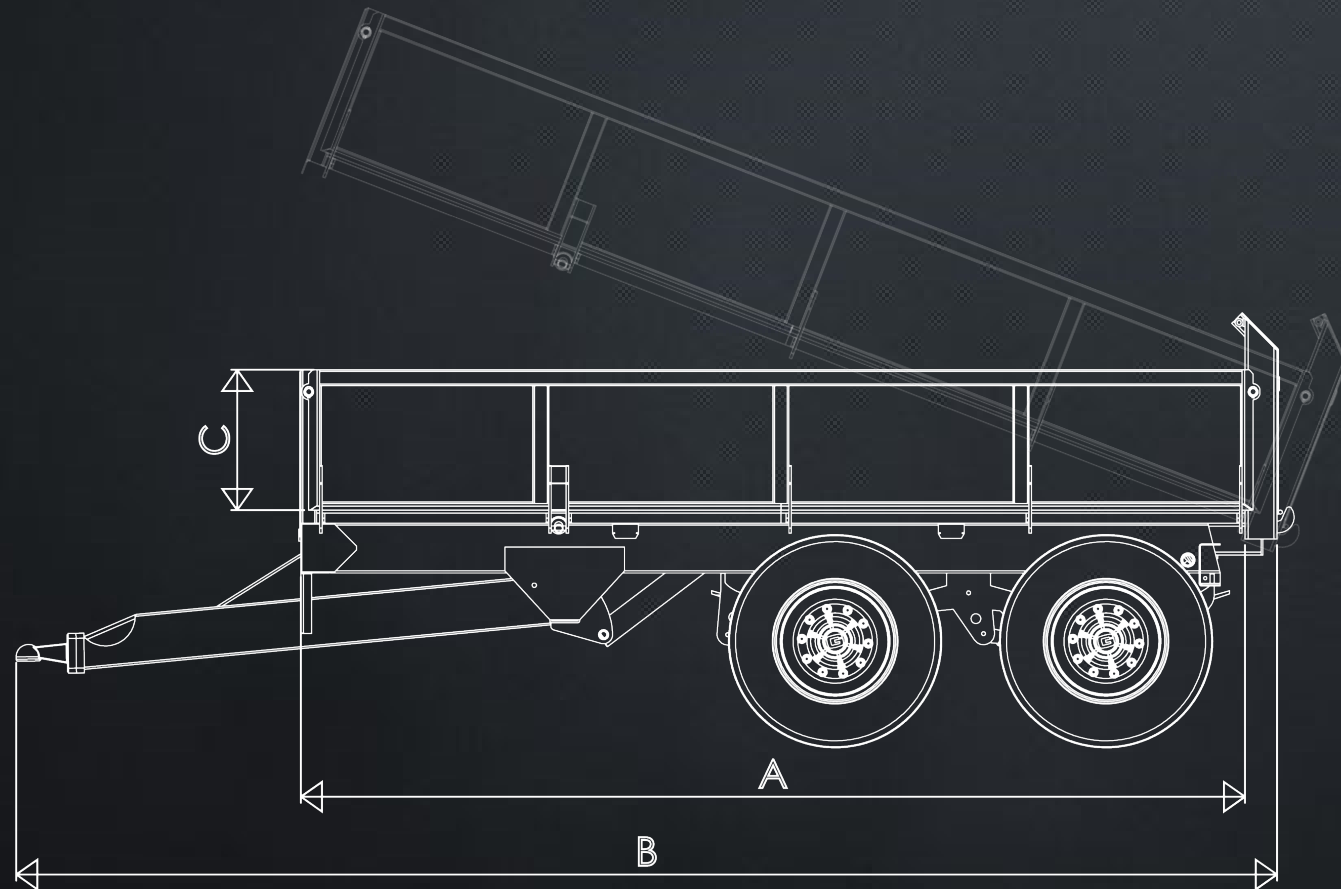

DSD18	Ref	18 Tonne
Body Length (inside)	A	4872mm
Overall Length	B	6296mm
Body Height (inside)	C	682mm
Body Width (inside)	D	2345mm
Body Width overall	D	2515mm
Tipping Height		