

STAINES WBDS

WATER BOWSER—DUST SUPPRESSION



Our Staines dust suppression water bowser are ideal for use in quarries, construction sites and other civil engineering projects. They have a PTO driven pump for powered discharge and a PTO driven vacuum pump for suction loading.

This 2,500 litre tanker with spinning disc attachment allows a full tank to last up to 90 minutes. Helping you implement best practice when it comes to environmental management on all sites.

TRAILER SPECIFICATION

Model	WBDS-S
Carrying Capacity	2,500-4,000 Gallon
Trailer Chassis	250 x 150 x 6mm RHS
Axles	10 stud commercial axles—180mm brakes
Suspension	Multi-leaf parabolic suspension
Tyres	560/60 R22.5
Braking	Air braking system with load sensing on air. Failsafe system Ratchet style park brake
Lighting	Fully legal commercial road lighting kit Connection to tractor Rear stop/ tail/ indicator/ flashing lights Front & Side marker lights Number plate holder & light
Paint	Twin pack polyurethane paint
Extras	Sprung drawbar Dribble bar Hydraulic pump



STAINES WBDS

WATER BOWSER—DUST SUPPRESSION

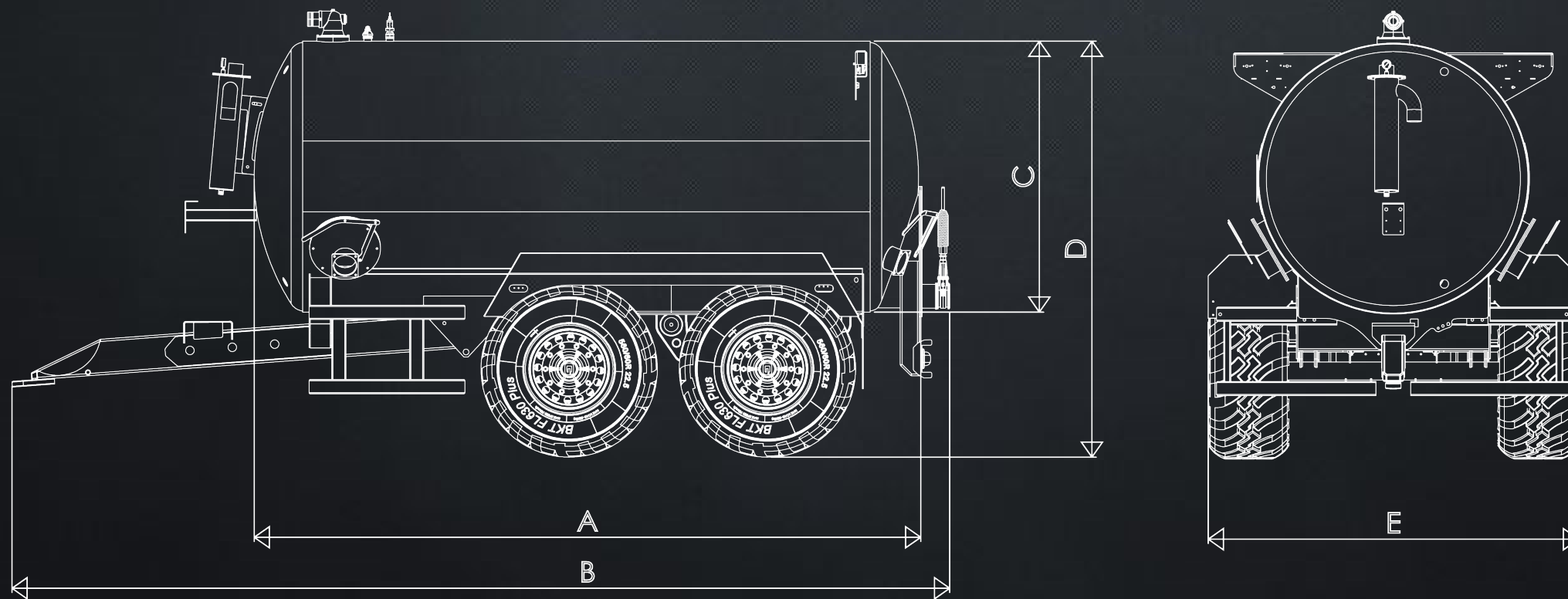

WBDS	Ref	
Tank Length	A	4700mm
Overall Length	B	6622mm
Tank Outer Diameter	C	1914mm
Tank Inner Diameter		1902mm
Trailer body Width	D	2938mm
Overall Trailer Height	E	2615mm